

# Challenges and Opportunities for DER Markets and DLMP

Hongyu Wu, PhD  
Assistant Professor  
Dept. of Electrical & Computer Engineering  
Kansas State University

Markets Session 3: Control and Dispatch of Hybrid Resources  
Tuesday, June 23, 2020

# Outline

- DER and distribution markets
- A component-wise DLMP model
- Distribution market clearing with DLMP
- Simulation results on IEEE 69-node system
- Conclusions, challenges and opportunities

*“Fundamental principles of rate design and, particularly, principles of good market design for efficient, organized markets for the sale and purchase of electric energy, require that allocation of costs follow causation of such costs as closely as possible” - FERC, Docket No. ER04-691-074*

# Distributed Energy Resources (DER)

- The power industry is undergoing transformation:
  - Shifting away from fossil fuels to renewables
  - Bottom-up proliferation of DERs
    - Electrification of transportation
    - Community microgrids
    - IoT-based smart buildings, homes, and cities
    - Smart inverters (Volt-Var, Volt-Watt controls)
  - Growth of a “behind-the-meter” market
- Reshaping the paradigm of distribution systems
  - Diverse electricity demand, distribution grid operations, planning, markets, business models, utility regulation, capital investment, ...

# Distribution Markets

- DER value proposition
  - Shape new loads to ease operational challenges
  - Provide add-on resilience to severe disruptions
  - Defer distribution infrastructure upgrades
- Stage-2 distribution market
  - DERs and end-customers become distribution grid resources
  - Energy and ancillary services at multiple timescales
  - Distribution market requires rate designs and **cost-causation** pricing of services

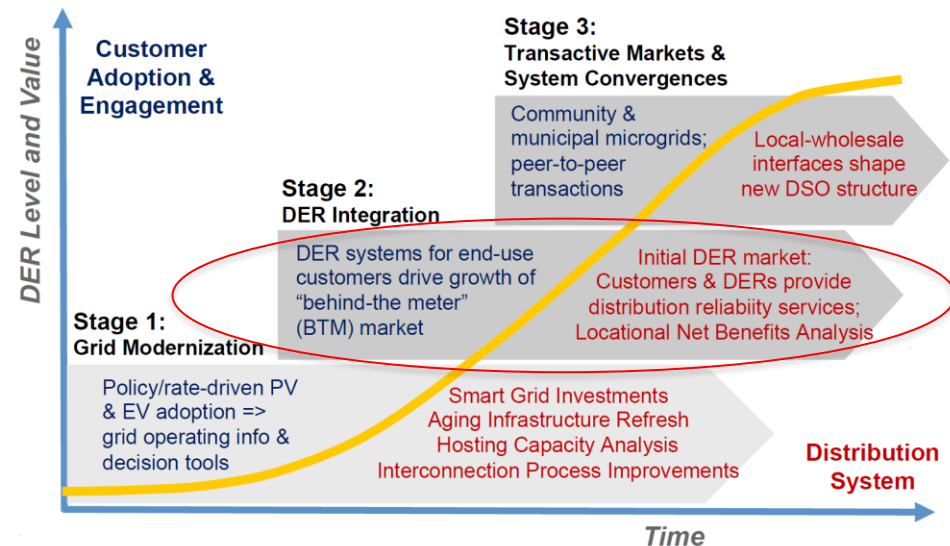

Fig. 1 Evolution of distribution market

Source: Lorenzo Kristov

*A research question is how to design a marginal-cost-based pricing mechanism*

# Distribution Locational Marginal Pricing (DLMP)

- A **granular, market measure** of the marginal cost at the specific **time** and **location** of the core electric product's use (e.g., energy, reactive power, and reserves from DERs)
- Different from administrative valuation approaches
  - LMP+D, feed-in tariff, net-metering, etc.
- Optimal power flow (OPF) model for distribution grids
  - DC-OPF model has significant errors and lacks losses, voltage violations, and reactive power pricing
  - Approximation of AC-OPF model has been widely adopted
  - Component-wise DLMP including **energy, loss, voltage violation,** and **congestion** prices

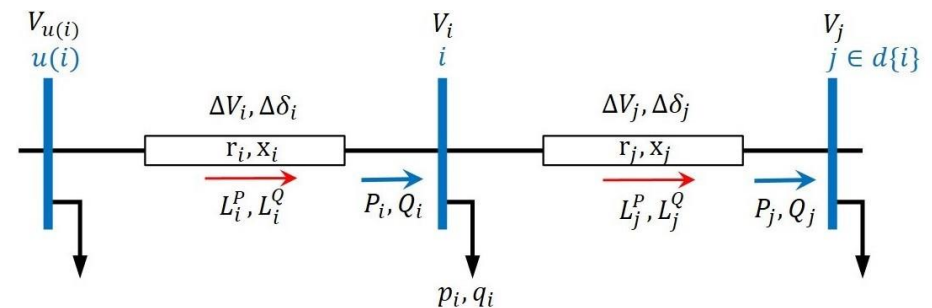

Fig. 2 A radial branch model

# Component-Wise DLMP

- **Real and reactive DLMP** is defined as the sum of energy, loss, voltage violation, and congestion prices
- **Energy component** is the shadow prices of the nodal real and reactive power balance constraints
- **Loss component** is derived using loss sensitivities with respect to nodal power injections
- **Voltage component** is derived using voltage sensitivities with respect to nodal power injections
- **Congestion component** is derived using lines' apparent power flow sensitivities with respect to nodal power injections



$$\Omega_{i,\phi,t}^P = \Omega_{i,\phi,t}^{EP} + \Omega_{i,\phi,t}^{LP} + \Omega_{i,\phi,t}^{VP} + \Omega_{i,\phi,t}^{CP}$$

$$\Omega_{i,\phi,t}^Q = \Omega_{i,\phi,t}^{EQ} + \Omega_{i,\phi,t}^{LQ} + \Omega_{i,\phi,t}^{VQ} + \Omega_{i,\phi,t}^{CQ}$$



$$\Omega_{i,\phi,t}^{LP} = \Omega_{i,\phi,t}^{EP} \sum_j \frac{\partial L_{j,\phi,t}^P}{\partial p_{i,\phi,t}} + \Omega_{i,\phi,t}^{EQ} \sum_j \frac{\partial L_{j,\phi,t}^Q}{\partial p_{i,\phi,t}}$$

$$\Omega_{i,\phi,t}^{LQ} = \Omega_{i,\phi,t}^{EQ} \sum_j \frac{\partial L_{j,\phi,t}^Q}{\partial q_{i,\phi,t}} + \Omega_{i,\phi,t}^{EP} \sum_j \frac{\partial L_{j,\phi,t}^P}{\partial q_{i,\phi,t}}$$



$$\Omega_{i,\phi,t}^{VP} = \sum_{i'} (\mu_{i,\phi,t}^{\min} - \mu_{i,\phi,t}^{\max}) \frac{\partial V_{i,\phi,t}}{\partial p_{i,\phi,t}}$$

$$\Omega_{i,\phi,t}^{VQ} = \sum_{i'} (\mu_{i,\phi,t}^{\min} - \mu_{i,\phi,t}^{\max}) \frac{\partial V_{i,\phi,t}}{\partial q_{i,\phi,t}}$$



$$\Omega_{i,\phi,t}^{CP} = \sum_{j \in u\{i\}} \rho_{i,\phi,t}^1 \frac{\partial S_{j,\phi,t}}{\partial p_{i,\phi,t}}$$

$$\Omega_{i,\phi,t}^{CQ} = \sum_{j \in u\{i\}} \rho_{i,\phi,t}^2 \frac{\partial S_{j,\phi,t}}{\partial q_{i,\phi,t}}$$



# Distribution Market Clearing Model

- Objective
  - minimize operating costs
- Constraints
  - power balance, losses, power flow, voltage, DER, demand, balancing constraints
- Segment-wise bidding
  - Conventional DG
  - Zero VRE bid
  - Price-responsive loads
  - Battery energy storage
    - Injection and extraction bids
- Uncertain VRE
  - Using a data-driven probability efficient point (PEP) method
  - Confidence level -  $\alpha$
  - Using historical VRE data

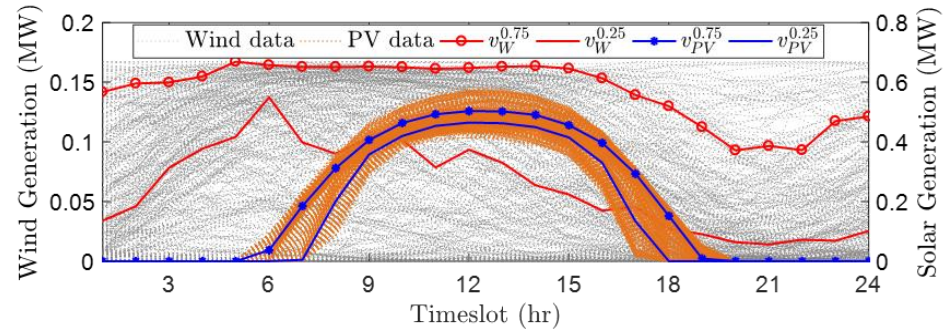

Fig. 3 Illustration of PEP on VRE

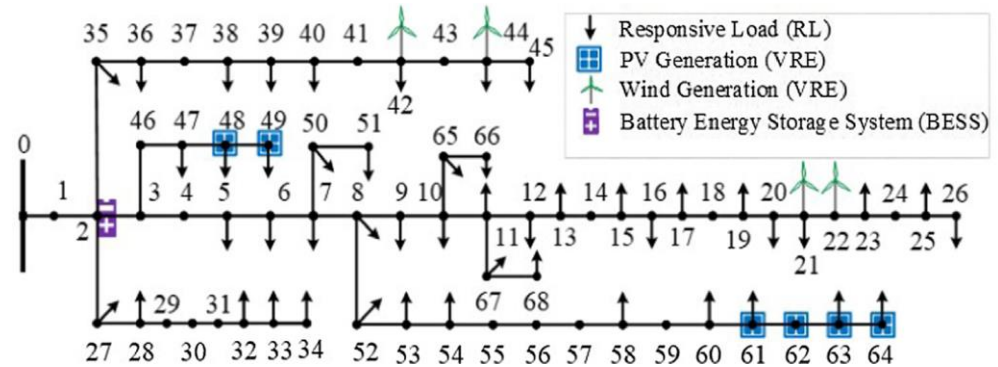

Fig. 4 Modified IEEE 69-node system

# Simulation Results – Balanced System

- In Scenario I, due to high demand, a voltage violation at node 64 and congested line 2 causes large voltage price (green) and congestion price (yellow)
- In Scenario II, increasing VRE removes the congestion and voltage violation prices

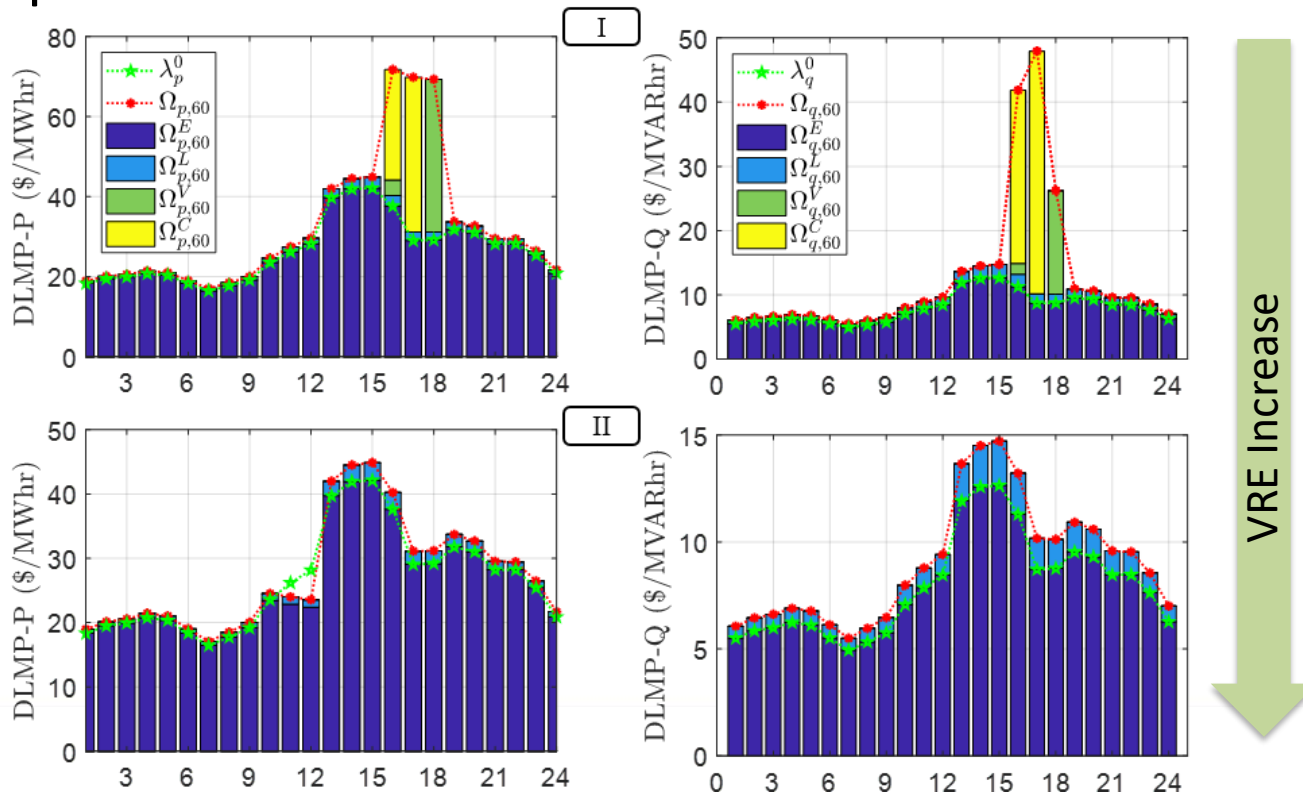

Fig. 5 Component-wise real and reactive DLMPs of node 60



# Simulation Results – Unbalanced System

- Consider a case where 28.5%, 2.6%, and 2.2% VRE portfolio for Phases A, B, and C
- Zero real DLMP: Zero-variable-cost VRE is the marginal unit supplying the next increment of real power
- Negative voltage components indicate system voltage profile would be improved if more energy were to be consumed

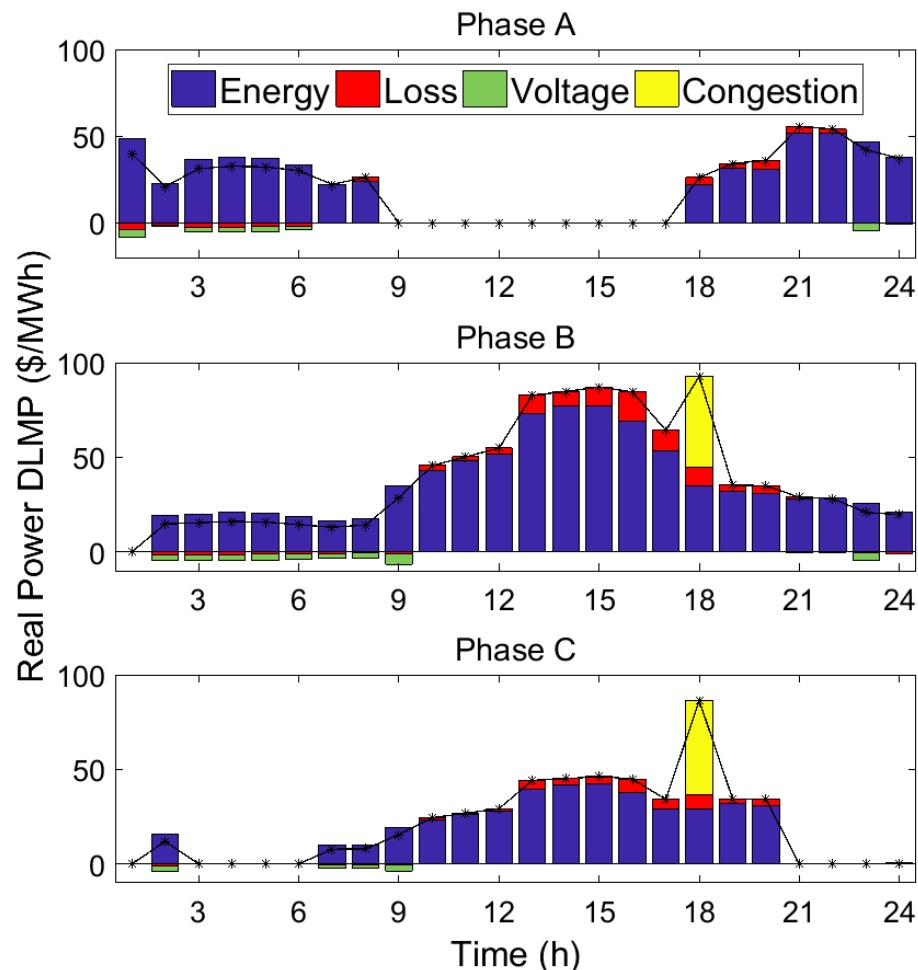
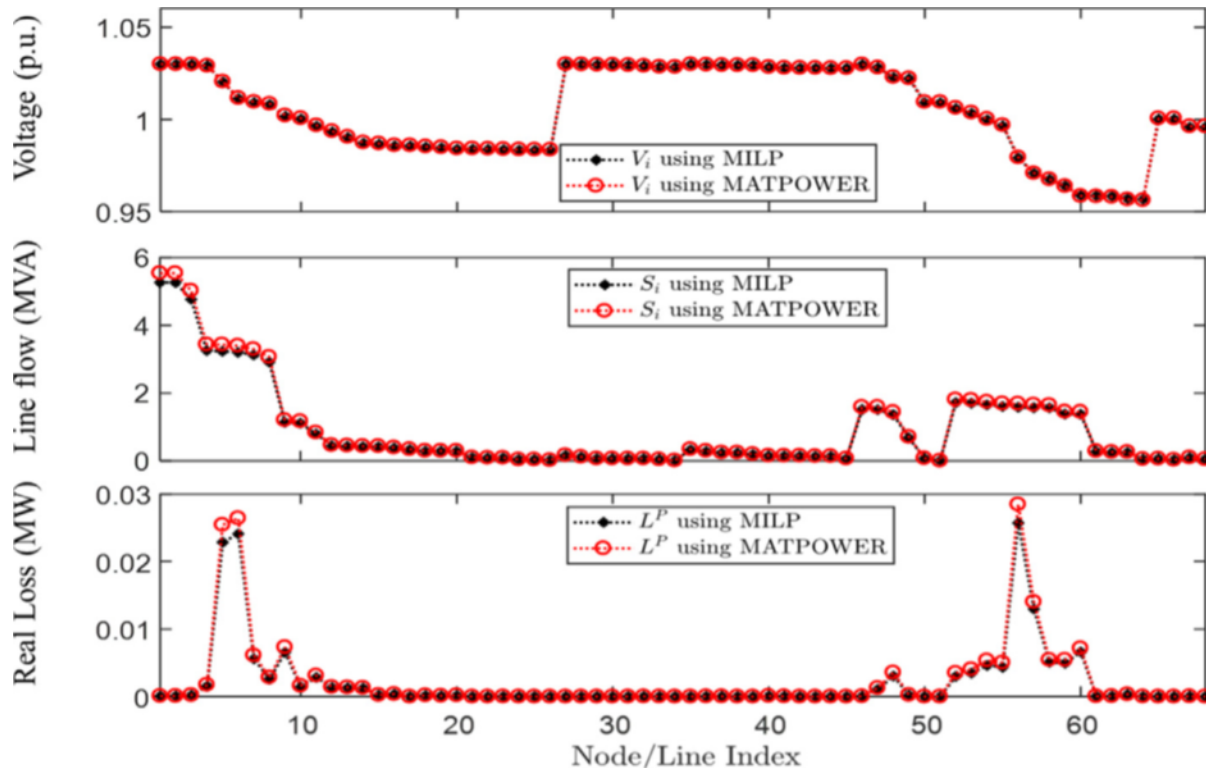

Fig. 6 Three-phase real component-wise DLMP at Node 8

# Model Validation

- Linear approximation vs. accurate AC-OPF model



	Max Error
Voltage	0.04%
Line Flow	1.34%
Line Losses	4.26%

*Approximation errors are insignificant and acceptable*

Fig. 7 Power flow comparison of approximated & full ACOPF

# Conclusions

- Opportunities
  - A cost-causation pricing mechanism
  - Enables marginal-cost-based prices reflecting the time- and location-specific value of real and reactive power
  - Energy, losses, voltage violation and congestion components promote economic efficiency by offering a clear price breakdown
  - DLMP-enabled markets for grid services help build DER commercial viability
  - Embraces smart inverter functions and demand diversification

# Conclusions

- Challenges
  - Uncertainty management for real-time reliability (better forecasting, advanced DLMP modeling)
  - Modeling accuracy, scalability and robustness
  - Other considerations
    - Incentives
    - Fairness

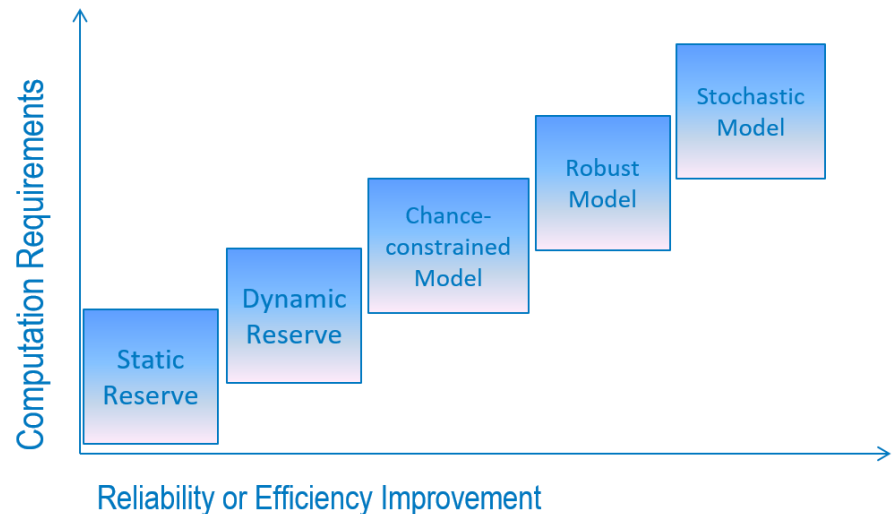

Fig. 8 Advanced modeling for DLMP



# Thank you !

Hongyu Wu

[hongyuwu@ksu.edu](mailto:hongyuwu@ksu.edu)

Smart Energy Systems Group at K-State

<http://www.ece.k-state.edu/psoc/>