



**NERC/NAGF/ESIG Workshop**  
**ISO/RTO Market Participation of**  
**Storage and Hybrids**

Kenneth Ragsdale, Principal, Market  
Design, ERCOT

September 18, 2019

# Outline – Storage in ERCOT (past, present and future)

1. Background, Past, Present and Future
2. Current “Work-Around” and current participation
  - a) Fast Responding Regulation Service (FRRS) [March 2014]
  - b) Connected to the transmission system
  - c) Connected to the distribution system (Generation Resources and Settlement Only Distributed Generation)
    1. “Equivalent modeling” versus “mapping”
    2. What is required from the DSPs?
3. Wholesale Storage Load treatment
4. Fast Frequency Response (FFR) ~ March 2020
5. DC-Coupled Resources --- Work in Progress
  1. Mostly modeled as two resources (PVGR and Battery)
  2. Seen as two resources from ERCOT’s Perspective

# Utility Scale Battery Additions by Year (as of July 31, 2019)

## ERCOT Battery Additions by Year (as of Jul 31, 2019)

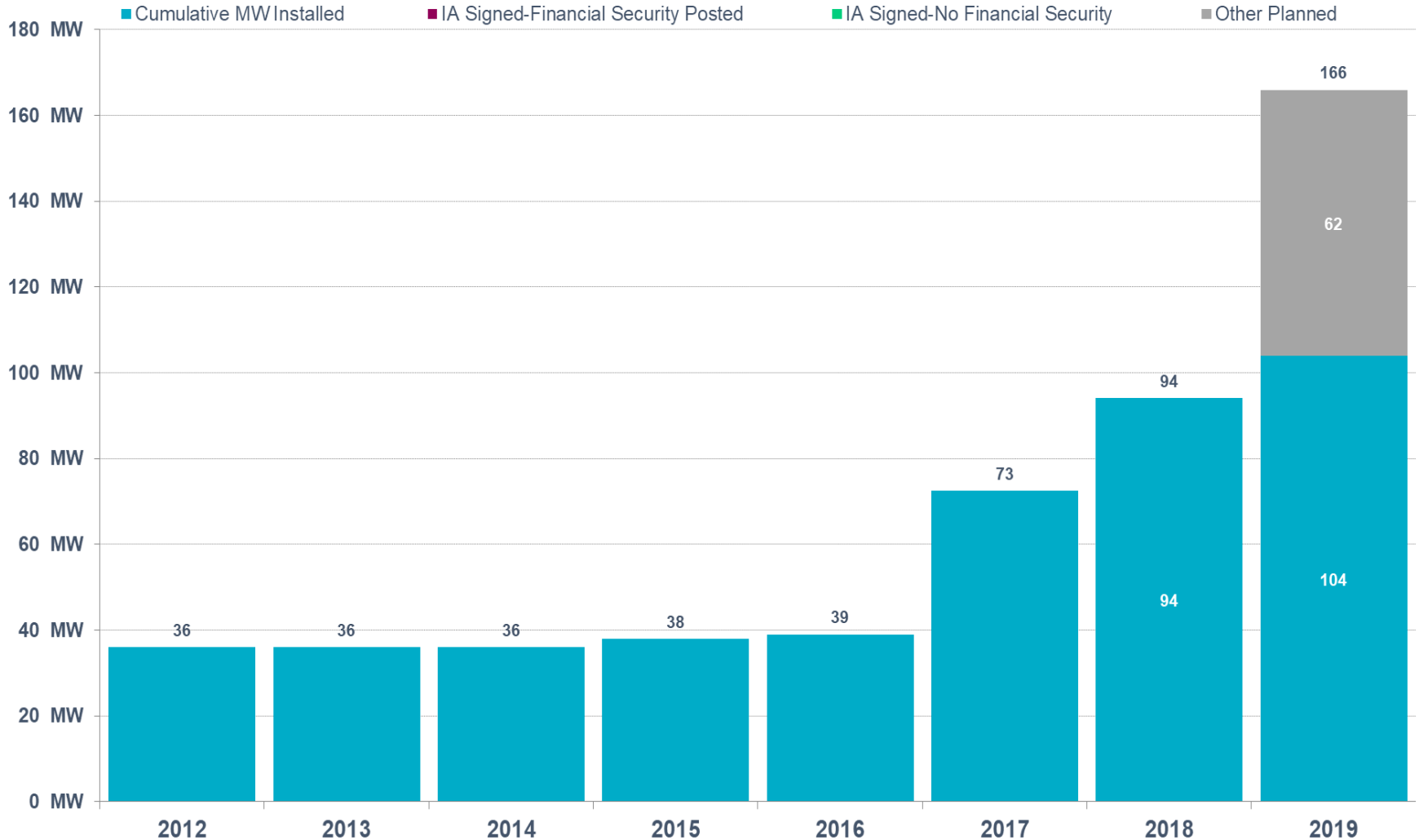

# Summary of Generation Interconnection Requests – as of 9-1-19

Fuel Type/ Technology Type	SS and FIS Completed IA (MW)	Grand Total (MW) In Progress
Natural Gas	608	7,599
<b>Internal Combustion</b>	<b>0</b>	<b>0</b>
<b>Wind</b>	9,073	<b>35,276</b>
<b>Solar</b>	3,283	<b>64,579</b>
Compressed Air Storage	0	608
Battery	0	<b>4,200</b>
Other		354
<b>Total</b>	<b>12,964</b>	<b>112,616</b>

Does not include project requests on the distribution system  
 SS = Security Screening Study  
 FIS = Full Interconnection Study  
 IA = Interconnection Agreement

# ERCOT Energy Storage Projects

## (per the GINR Project Details (as of 9-1-19))

ID#	INR	Project Name	Interconnecting Entity	County	CDR Reporting Zone	Projected COD	Capacity (MW)
1	21INR0357	SP TX-12B Phase IV	CED Upton County Solar, LLC	Upton	WEST	06/01/2020	25
2	20INR0146	Angus Storage	Cypress Creek Renewables	Bosque	NORTH	08/31/2020	63
3	20INR0246	Ryan Energy Storage	Arrowhead Storage LLC	Coryell	NORTH	08/31/2020	47
4	20INR0280	High Lonesome BESS	HIGH LONESOME WIND POWER, LLC	Crockett	WEST	10/30/2020	50
5	20INR0281	Queen BESS	Roadrunner Solar Project, LLC	Upton	WEST	10/30/2020	50
6	20INR0089	Chisholm Grid	Able Grid Energy	Tarrant	NORTH	11/20/2020	200
7	20INR0268	Big Hat	Pyron Wind Farm, LLC	Nolan	WEST	12/01/2020	30
8	20INR0150	Robles Storage	Cypress Creek Renewables	Dimmit	SOUTH	12/31/2020	100
9	20INR0276	North Fork	Energy Storage Resources, LLC	Williamson	SOUTH	12/31/2020	100
10	20INR0288	Brazos BESS 2	Brazos Wind Ventures, LLC	Borden	WEST	12/31/2020	50
11	20INR0220	Eunice Storage	2W Permian Solar LLC	Andrews	WEST	12/31/2020	40
12	19INR0188	Millhouse Storage	Cypress Creek Renewables	Jim Wells	SOUTH	12/31/2020	38
13	20INR0135	Half Moon Battery	Nextera	Hidalgo	SOUTH	12/31/2020	30
14	21INR0035	Elmer	Energy Storage Resources, LLC	Tarrant	NORTH	01/31/2021	100
15	21INR0028	El Zorro Storage	Cypress Creek Renewables	Webb	SOUTH	02/01/2021	127
16	21INR0364	Gambit	Energy Storage Resources, LLC	Brazoria	COASTAL	03/31/2021	100
17	21INR0365	Bat Cave	Energy Storage Resources, LLC	Mason	SOUTH	03/31/2021	100
18	20INR0244	Montezuma Storage	Montezuma Storage LLC	Colorado	SOUTH	04/01/2021	47
19	20INR0245	Volunteer Storage	Blackjack Storage LLC	Caldwell	SOUTH	05/01/2021	47
20	21INR0244	Madero Grid	Madero Grid, LLC	Hidalgo	SOUTH	05/31/2021	202
21	21INR0027	Zier Storage	Cypress Creek Renewables	Kinney	SOUTH	05/31/2021	20
22	21INR0430	Holstein 2 Energy Storage	229HD 8me LLC	Nolan	WEST	06/01/2021	100
23	22INR0206	Inverter Field Storage	CG WHARTON COUNTY LLC	Wharton	SOUTH	06/01/2021	80
24	21INR0260	Chariot Storage	Chariot Storage LLC	Limestone	NORTH	06/18/2021	47
25	21INR0281	Byrd Ranch Storage	Byrd Ranch Storage LLC	Brazoria	COASTAL	06/18/2021	47
26	21INR0280	Edgewater Storage	Edgewater Battery Storage LLC	Ellis	NORTH	06/28/2021	47
27	21INR0363	Carol Battery	Goat Mountain Renewables, LLC	Potter	PANHANDLE	06/30/2021	168
28	19INR0176	Roughneck Storage	Glidepath	Brazoria	COASTAL	07/01/2021	50
29	21INR0033	Red Holly Storage	GreenGo Energy	Dawson	WEST	07/01/2021	50
30	21INR0029	Green Holly Storage	GreenGo Energy	Dawson	WEST	08/01/2021	50
31	21INR0258	Mercury Storage	Mercury Storage, LLC	Hill	NORTH	12/01/2021	206
32	21INR0262	King Mountain Storage	King Mountain Storage LLC	Upton	WEST	12/01/2021	206
33	21INR0411	Galloway 2 Storage	224WB 8ME LLC	Concho	WEST	12/01/2021	110
34	20INR0238	Space City Storage	EDF Renewables Development, Inc.	Wharton	SOUTH	12/01/2021	50
35	21INR0345	Lunis Creek Storage 1	Lunis Creek Solar Project, LLC	Jackson	SOUTH	12/31/2021	81
36	21INR0347	Lunis Creek Storage 2	Lunis Creek Solar Project II, LLC	Jackson	SOUTH	12/31/2021	81
37	20INR0100	Westoria Storage	Brazoria West Solar Project, LLC	Brazoria	COASTAL	12/31/2021	58
38	21INR0412	Dexter Storage	241BB 8ME LLC	Runnels	WEST	06/01/2022	325
39	21INR0209	Adamstown Storage	Adams Creek Solar Project, LLC	Wichita	WEST	12/31/2022	116
							<b>3439</b>



# Energy Storage Resources: Current Approach

Resource Entity must register  
Storage Resource as a  
**Controllable Load Resource (L2)**  
&  
**Generation Resource (G2)**

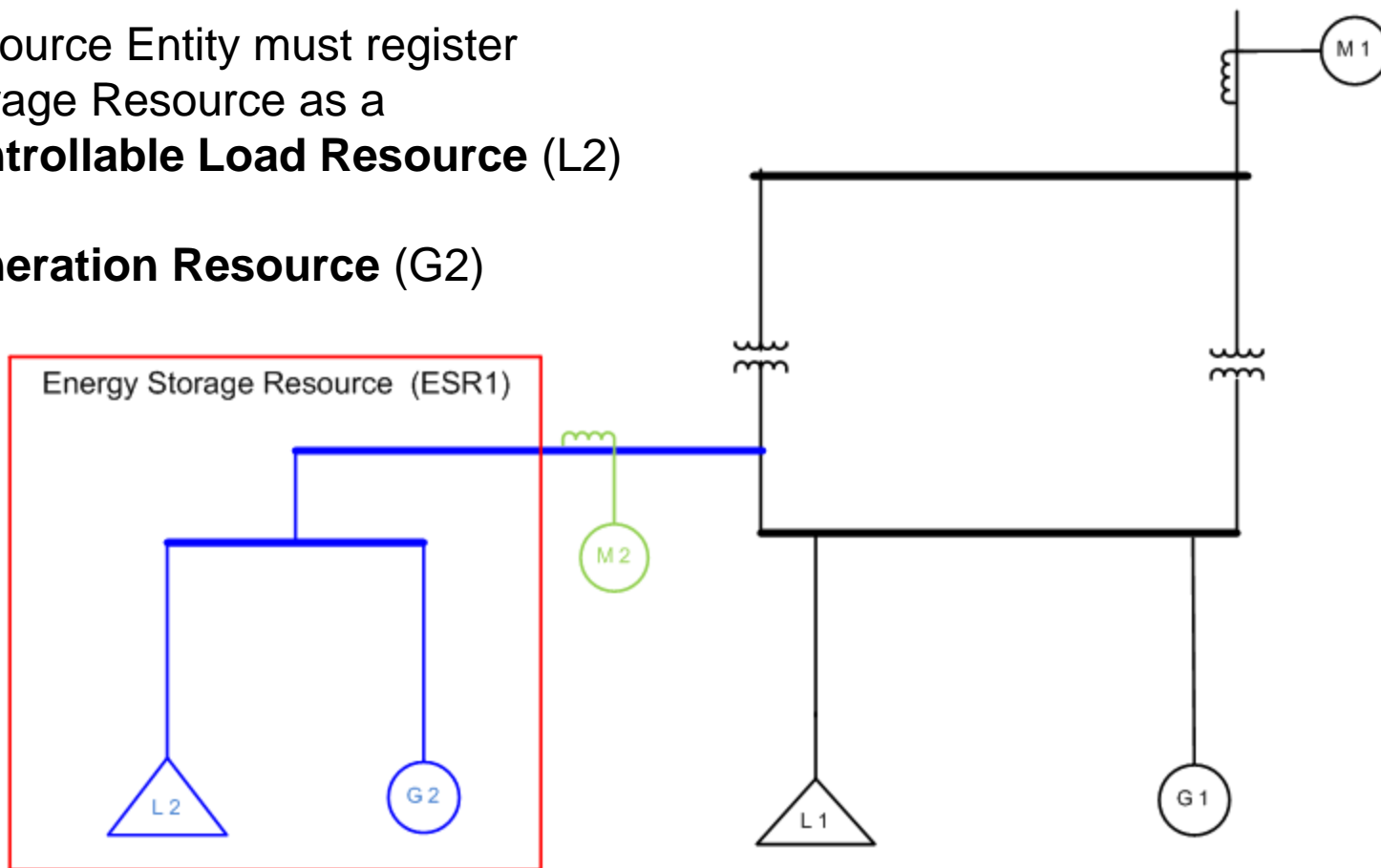

# Energy Storage Resources: Proposed

Resource Entity must register Storage Resource as a **Single Device**

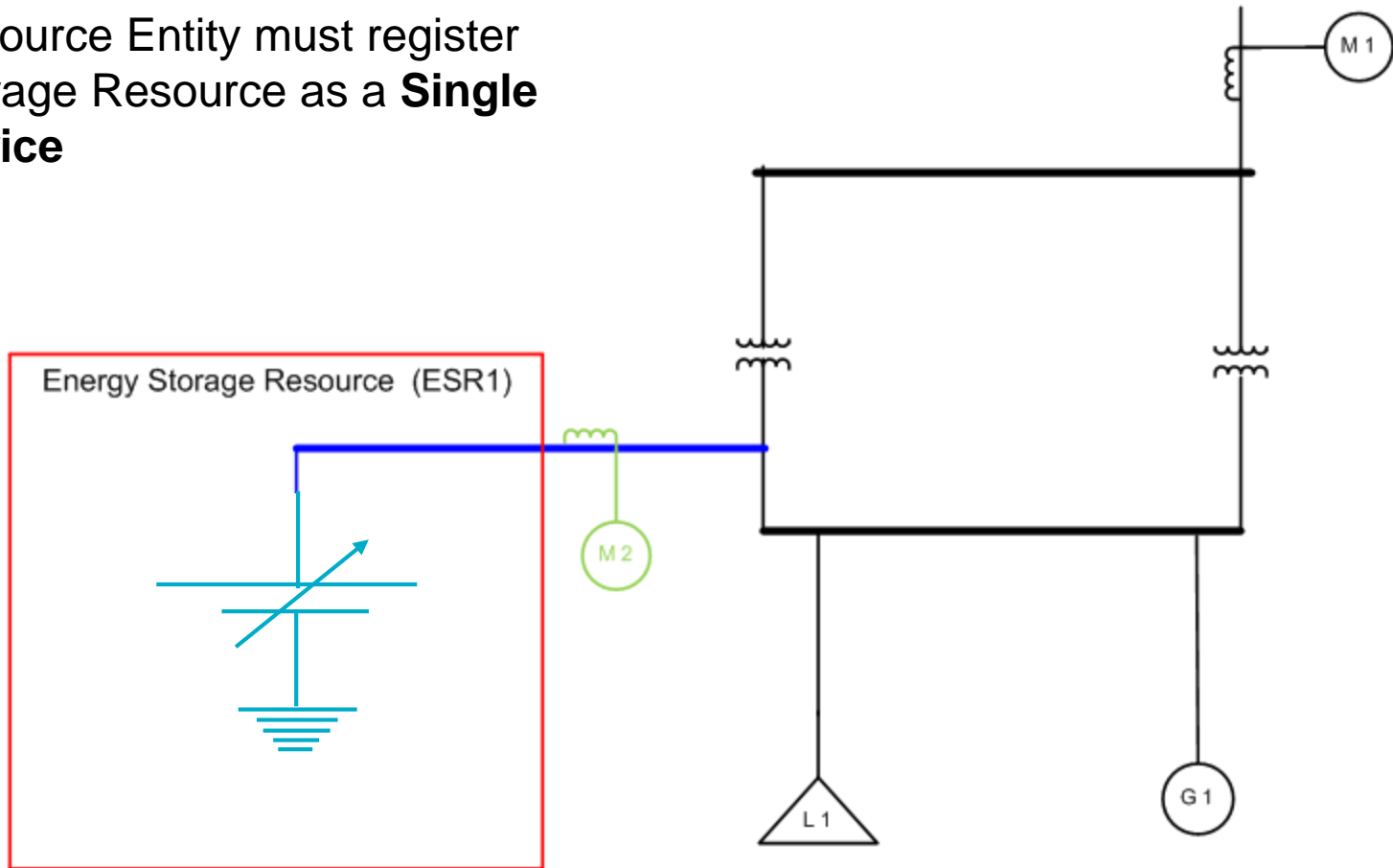

# AC Coupled Resource (Solar + Battery)

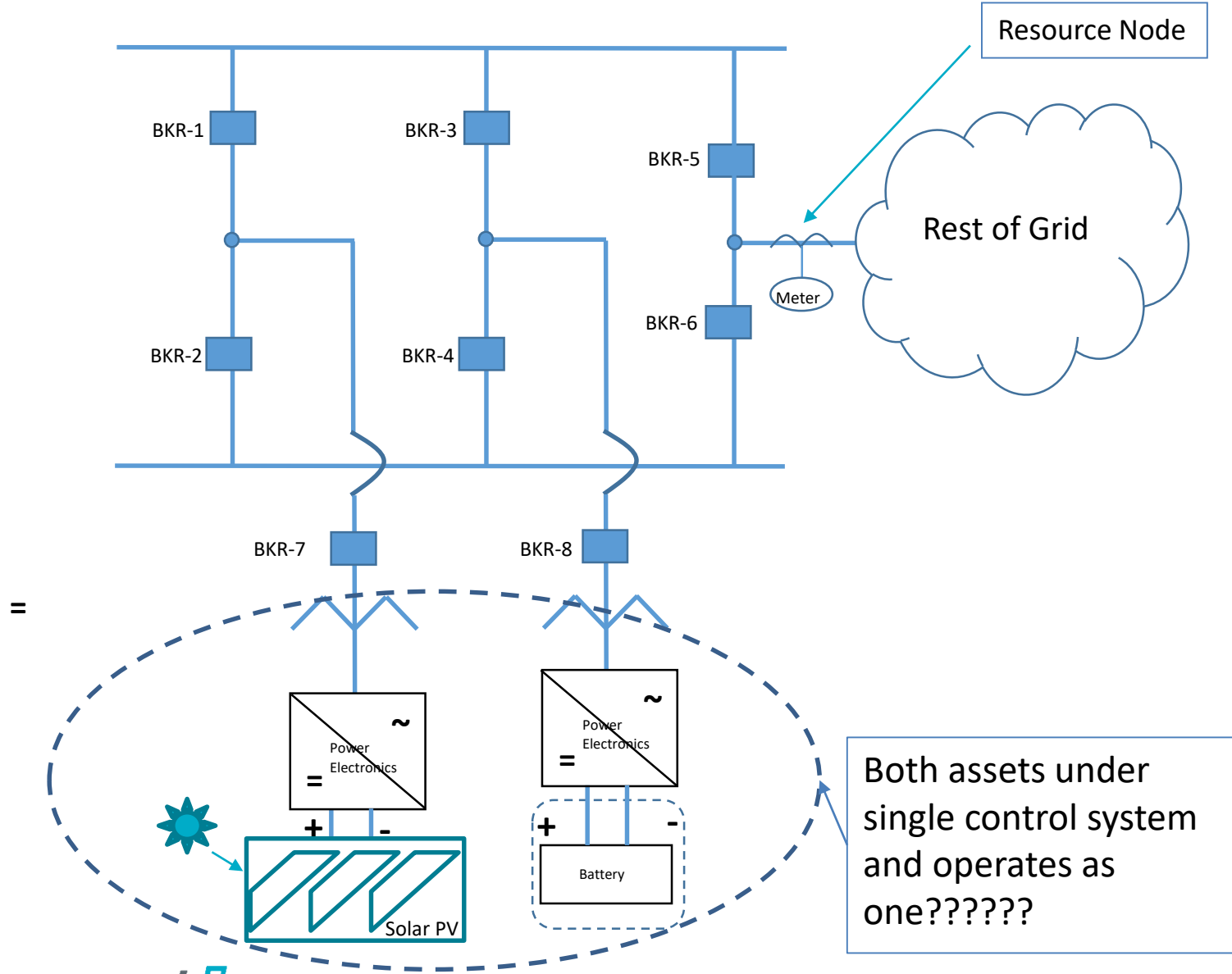



# DC Coupled Resource (Solar + Battery)

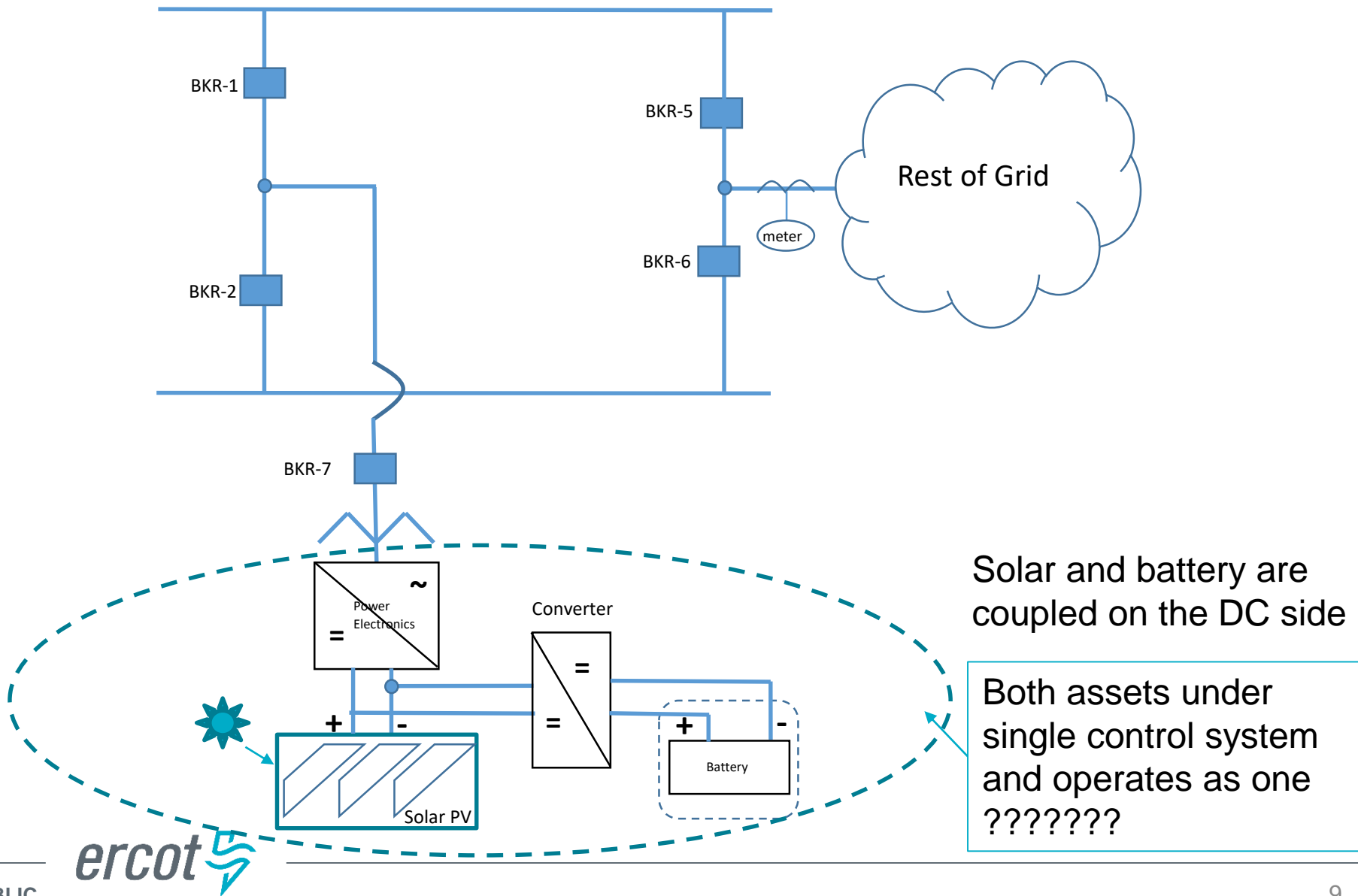

# How is a DC-Coupled Resource Registered and Modeled?

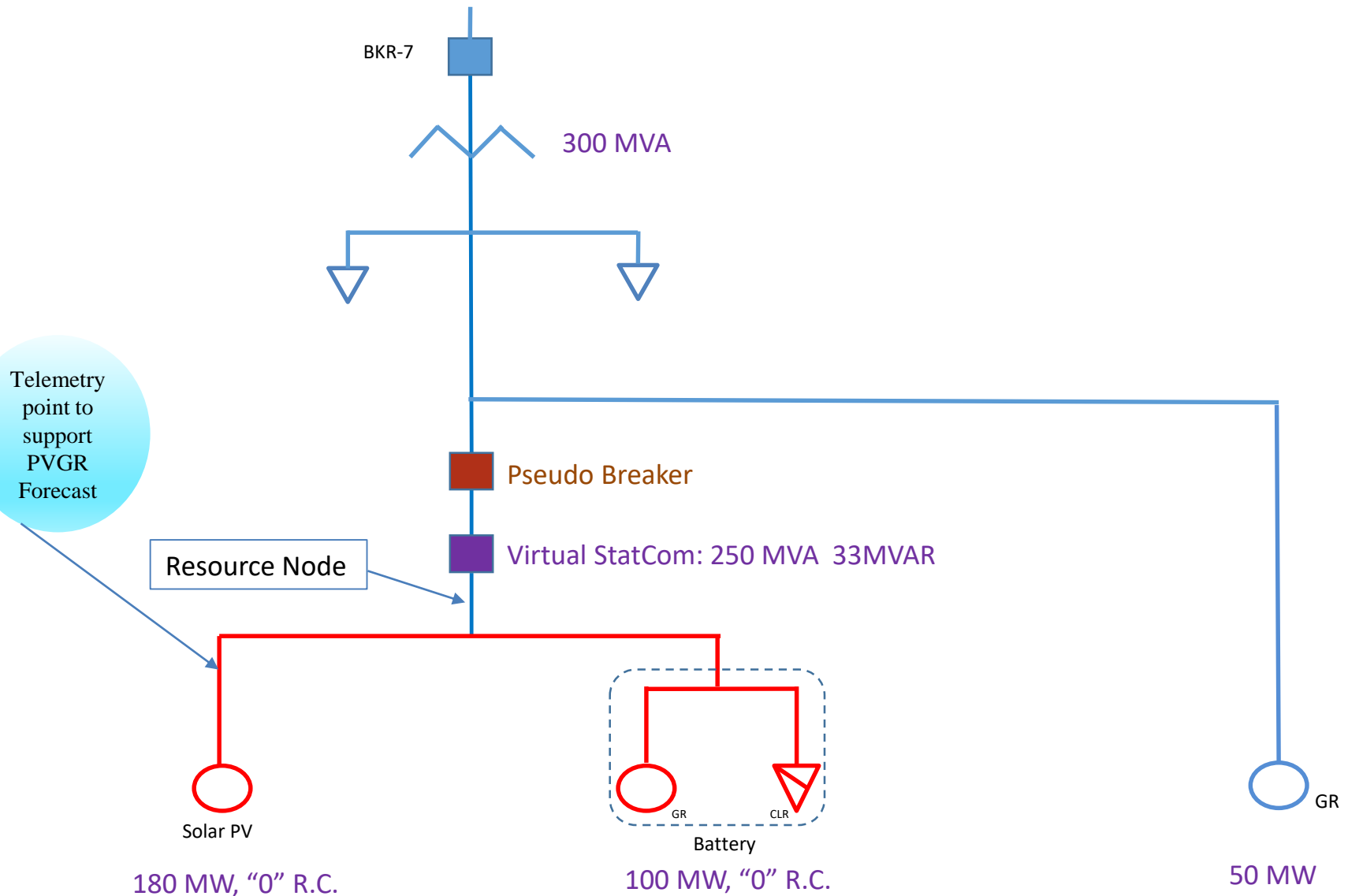

# Thank you! Questions?



Kenneth Ragsdale

[kragdsdale@ercot.com](mailto:kragdsdale@ercot.com)