



Session A-4

Black Start and System Restoration with Wind and Solar

Sebastian Achilles
sebastian.achilles@ge.com
GE Energy Consulting

March 15 2018

Power System Restoration (PSR) With renewables

- A PSR plan includes several stages:
 - Starting Black Start unit(s)
 - Energize system to No-Black Start units
 - Load restoration for stable operation of Black Start unit(s)
 - Start selected No-Black Start
 - Load Restoration for stable operation
 - Island synchronization
- Limited research material on using Wind or PV solar for PSR
- Usually renewables are disconnected until late stages of a PSR plan

Wind and Solar: Black Start?

- Wind and solar generation converters typically include **fast active and reactive current controls** and require **synchronization** with the grid voltages

Reactive and Active Current commands

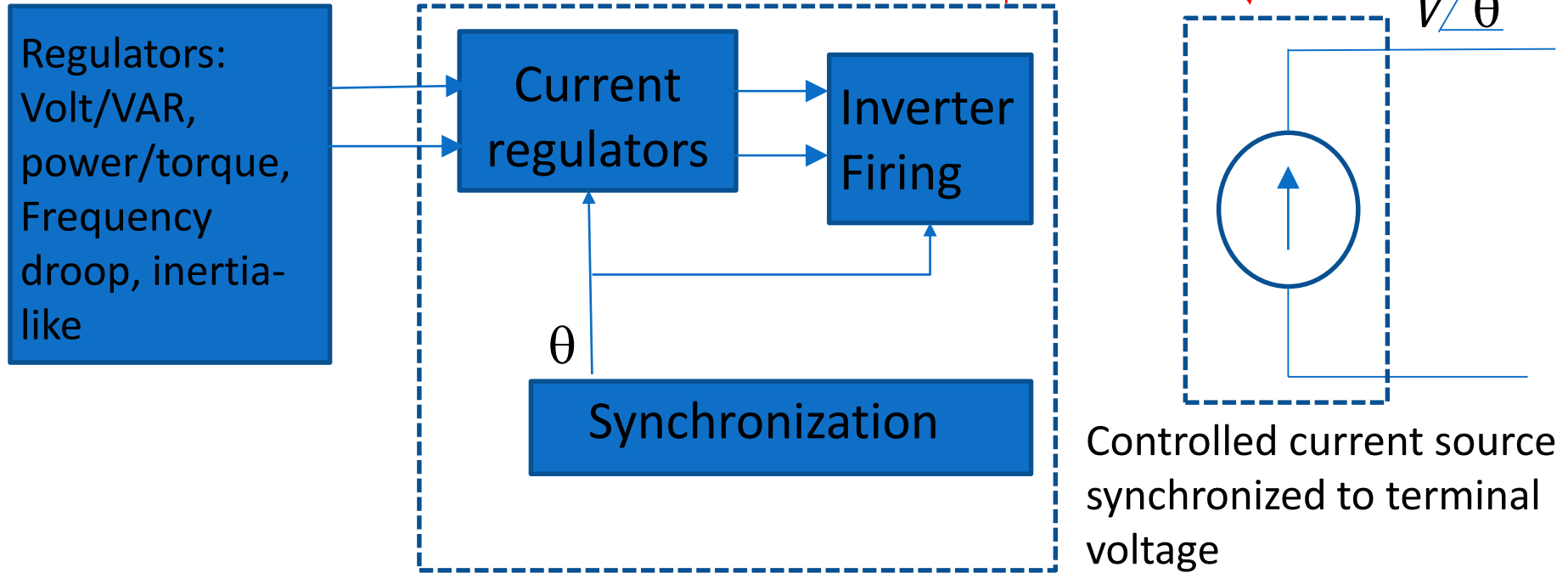

No black start capability in current offerings

Black Start with Inverter Based Source

- Battery Energy Storage System of 30MW/22MWh



Imperial Irrigation District (IID) 30MW/20MWh BESS project

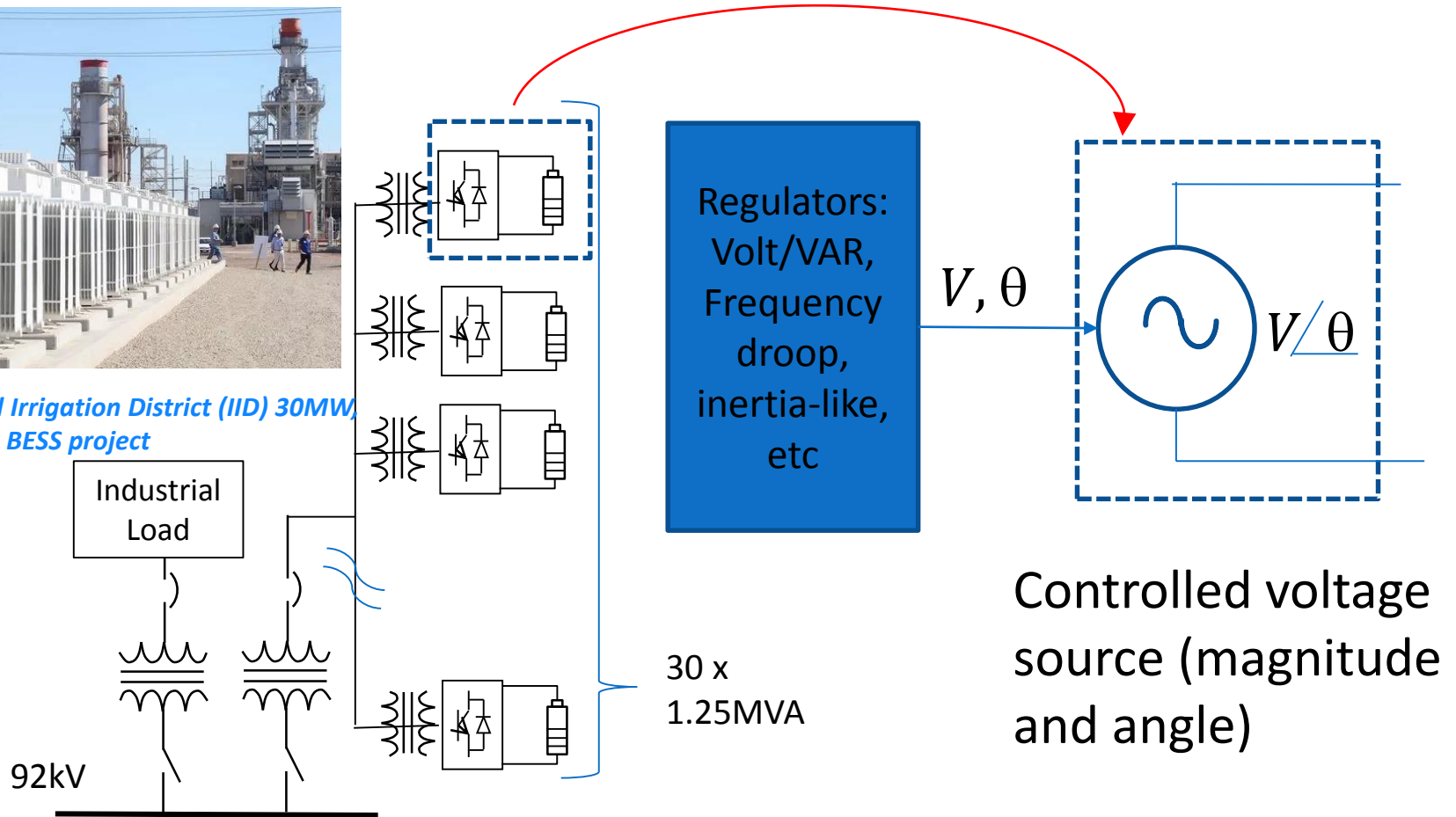

Fundamental control modification

Black Start with Wind and Solar

- Key control challenges:
 - Complex inverter products engineered to meet large number of grid requirements. Modification of inner loops requires significant engineering efforts and potentially hardware modifications.
 - Load/Generation balance is more complex than with BESS
 - Drive train oscillations and fast power fluctuations(wind)
- Other Challenges: Motivation to manufacturers



Final Remarks

- Wind and Solar generation used in MW scale applications cannot Black Start with **present control approach**.
- Developing robust grid forming capabilities in wind and solar for black start are substantial
 - Potential cost impacts need to be considered
 - Incentive to manufacturers may be low.
- **Power balance during early stage of PSR** is complex even without variability of resources.
- In a 100% converter fed generation system, PSR could be supported with renewables and AC-coupled or DC-coupled battery systems with grid forming capabilities.
- Lots of work needed to do PSR without (or with less) conventional generation:
 - Control technology for large scale PV Solar or Wind,
 - Incentives to deploy systems with these capabilities
 - Incentives to operate and install systems with BESS to keep enough charge to support PSR
 - Manage available Wind and Solar resources and loads during early PSR stages

